

net 70 Fr

Service
Service
Service

Information

1986-08-14

CDM2

A86-132

For the time being another servo panel is being mounted in players equipped with the CDM-2 Top HiFi. This panel is recognizable to the 12-digits number 3104 103 34180 etched in the track pattern.

In the manual this panel has been stated under the description **SERVO + PRE-AMPLIFIER IIA.**

For this reason the pages enclosed should be added to the manual.

Additional pages:

5-6-a1 5-6-a2
5-6-a3 5-6-a4



SERVO + PRE-AMPLIFIER PCB IIA

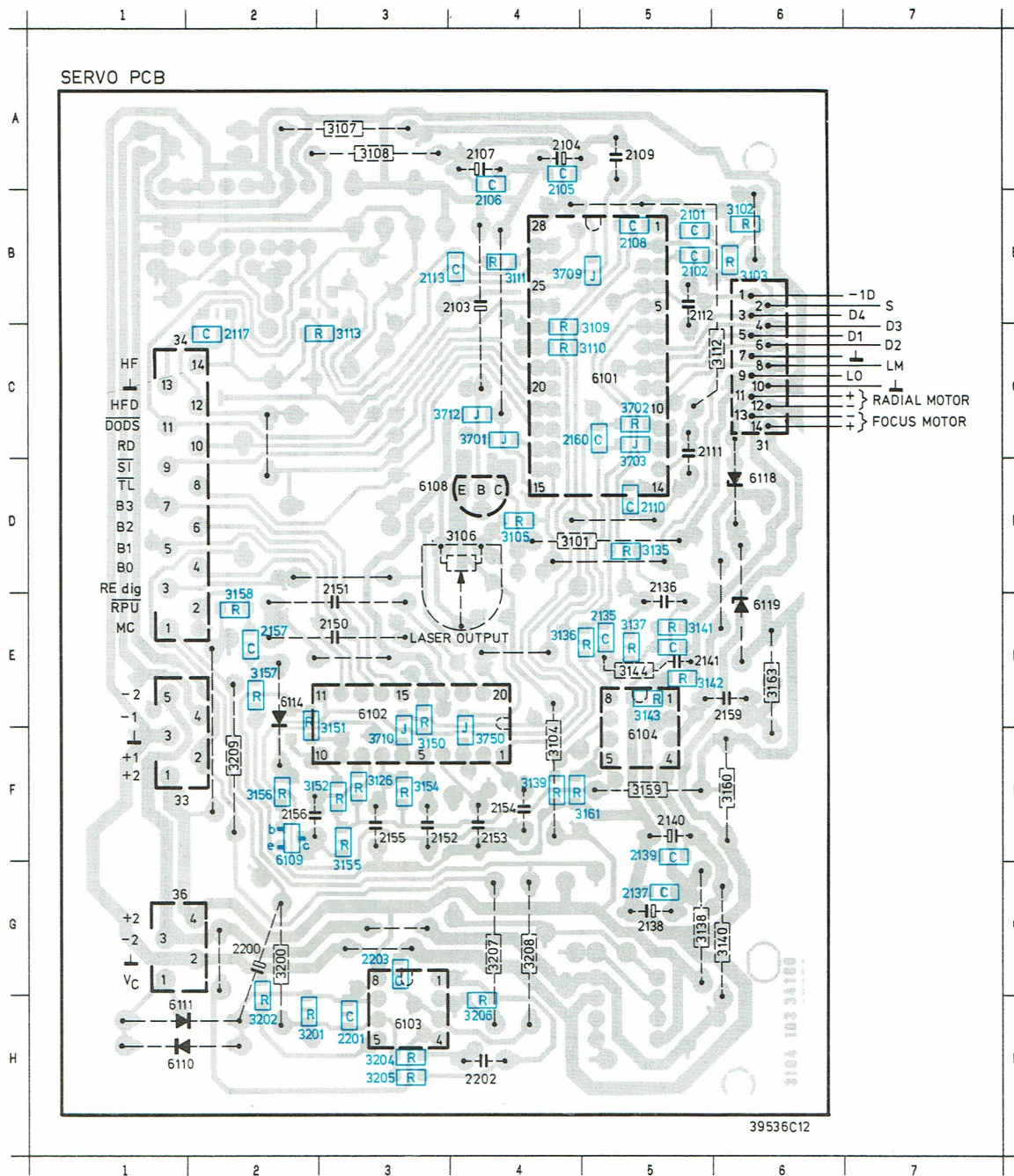

2101	3701	C	4
2102	3702	C	4
2103	3703	C	4
2104	3704	C	4
2105	3705	C	4
2106	3706	C	4
2107	3707	C	4
2108	3708	C	4
2109	3709	C	4
2110	3710	C	4
2111	3711	C	4
2112	3712	C	4
2113	3713	C	4
2114	3714	C	4
2115	3715	C	4
2116	3716	C	4
2117	3717	C	4
2118	3718	C	4
2119	3719	C	4
2120	3720	C	4
2121	3721	C	4
2122	3722	C	4
2123	3723	C	4
2124	3724	C	4
2125	3725	C	4
2126	3726	C	4
2127	3727	C	4
2128	3728	C	4
2129	3729	C	4
2130	3730	C	4
2131	3731	C	4
2132	3732	C	4
2133	3733	C	4
2134	3734	C	4
2135	3735	C	4
2136	3736	C	4
2137	3737	C	4
2138	3738	C	4
2139	3739	C	4
2140	3740	C	4
2141	3741	C	4
2142	3742	C	4
2143	3743	C	4
2144	3744	C	4
2145	3745	C	4
2146	3746	C	4
2147	3747	C	4
2148	3748	C	4
2149	3749	C	4
2150	3750	C	4
2151	3751	C	4
2152	3752	C	4
2153	3753	C	4
2154	3754	C	4
2155	3755	C	4
2156	3756	C	4
2157	3757	C	4
2158	3758	C	4
2159	3759	C	4
2160	3760	C	4
2161	3761	C	4
2162	3762	C	4
2163	3763	C	4
2164	3764	C	4
2165	3765	C	4
2166	3766	C	4
2167	3767	C	4
2168	3768	C	4
2169	3769	C	4
2170	3770	C	4
2171	3771	C	4
2172	3772	C	4
2173	3773	C	4
2174	3774	C	4
2175	3775	C	4
2176	3776	C	4
2177	3777	C	4
2178	3778	C	4
2179	3779	C	4
2180	3780	C	4
2181	3781	C	4
2182	3782	C	4
2183	3783	C	4
2184	3784	C	4
2185	3785	C	4
2186	3786	C	4
2187	3787	C	4
2188	3788	C	4
2189	3789	C	4
2190	3790	C	4
2191	3791	C	4
2192	3792	C	4
2193	3793	C	4
2194	3794	C	4
2195	3795	C	4
2196	3796	C	4
2197	3797	C	4
2198	3798	C	4
2199	3799	C	4
2200	3800	C	4
2201	3801	C	4
2202	3802	C	4

PRS.01572
 DRA AA-1
 T12/633
 BF.H. BIJ 39536C

SERVO + PRE-AMPLIFIER PCB IIA

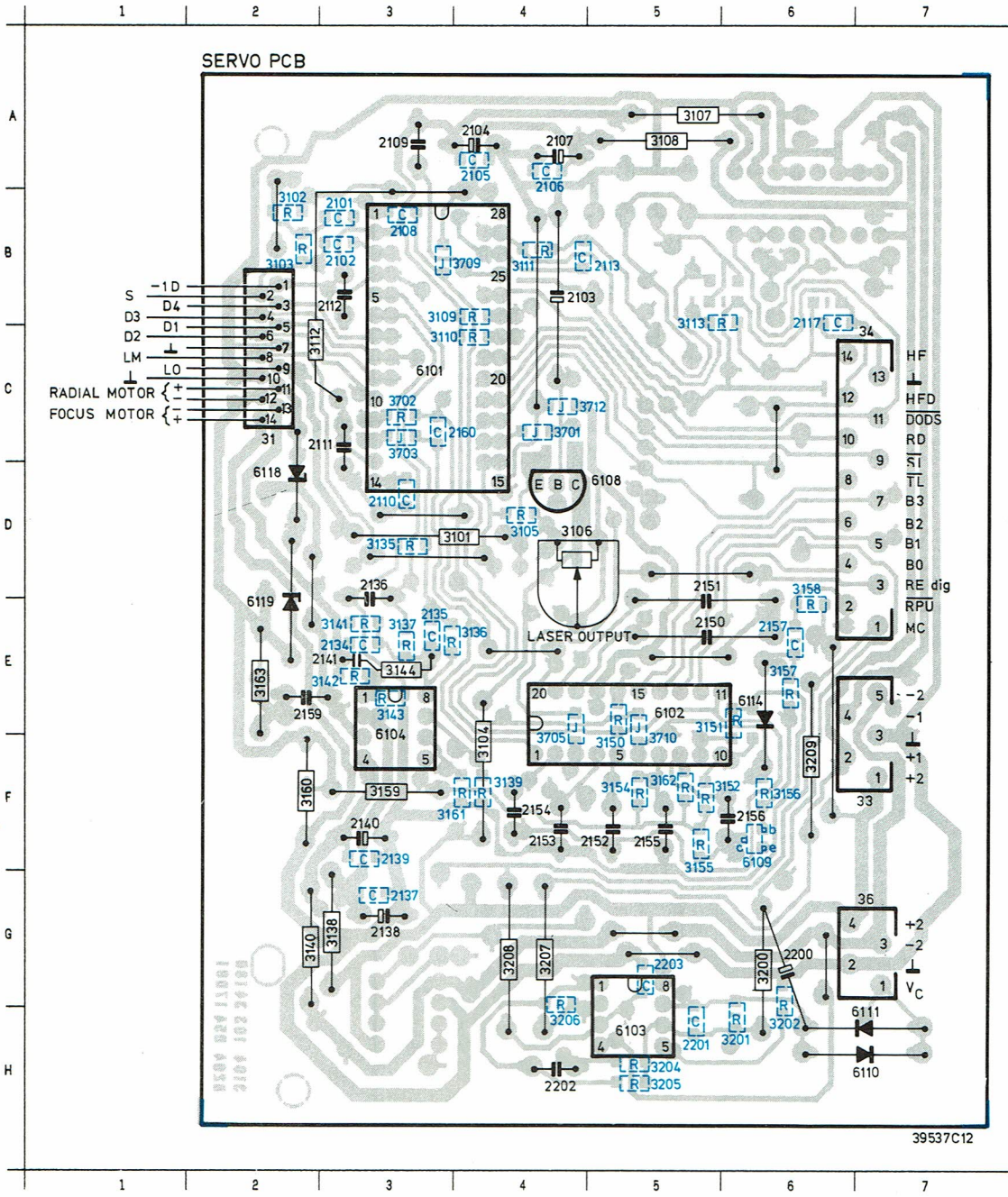

2101	B	3208	G	4
2102	B	3209	F	4
2103	B	3701	C	4
2104	B	3702	C	4
2105	B	3703	C	4
2106	B	3705	C	4
2107	B	3709	E	4
2108	B	3710	F	4
2109	B	3712	F	4
2110	B	C101	F	4
2111	B	C102	F	4
2112	B	C103	F	4
2113	B	C104	F	4
2117	B	C108	F	4
2134	B	C109	F	4
2135	B	6110	F	4
2136	B	6111	F	4
2137	B	6114	F	4
2138	B	6118	F	4
2139	B	6119	F	4
2140	B			
2141	B			
2150	B			
2151	B			
2152	B			
2153	B			
2154	B			
2155	B			
2156	B			
2157	B			
2159	B			
2160	B			
2200	B			
2201	B			
2202	B			
2203	B			
3101	B			
3102	B			
3103	B			
3104	B			
3105	B			
3106	B			
3107	B			
3108	B			
3109	B			
3110	B			
3111	B			
3112	B			
3113	B			
3114	B			
3115	B			
3116	B			
3117	B			
3118	B			
3119	B			
3120	B			
3121	B			
3122	B			
3123	B			
3124	B			
3125	B			
3126	B			
3127	B			
3128	B			
3129	B			
3130	B			
3131	B			
3132	B			
3133	B			
3134	B			
3135	B			
3136	B			
3137	B			
3138	B			
3139	B			
3140	B			
3141	B			
3142	B			
3143	B			
3144	B			
3145	B			
3146	B			
3147	B			
3148	B			
3149	B			
3150	B			
3151	B			
3152	B			
3153	B			
3154	B			
3155	B			
3156	B			
3157	B			
3158	B			
3159	B			
3160	B			
3161	B			
3162	B			
3163	B			
3164	B			
3165	B			
3166	B			
3167	B			
3168	B			
3169	B			
3170	B			
3171	B			
3172	B			
3173	B			
3174	B			
3175	B			
3176	B			
3177	B			
3178	B			
3179	B			
3180	B			

PRS.01573
 DRA AA-1
 TI2/633
 BEH. BI J 39537C

1001	J 2	2102	F 3	2106	B 4	2110	E 6	2116	E10	2137	J14	2141	K15	2153	H15	2157	I17	2202	M17	3103	F 3	3107	C 3	3111	D16	3136	J
1002	J 1	2103	J 3	2107	B 3	2111	E 8	2117	H10	2138	J14	2150	H14	2154	H15	2159	E21	2203	M16	3104	I 3	3108	C 3	3112	D16	3137	K
1003	J 1	2104	D 3	2108	E 9	2112	F10	2134	K15	2139	K14	2151	H14	2155	F18	2200	L18	3101	J 3	3105	K 4	3109	C 3	3113	D16	3138	L
2101	F 3	2105	D 4	2109	I10	2113	F 8	2136	K 9	2140	K14	2152	C14	2156	F18	2201	K18	3102	E 3	3106	K 3	3110	C 3	3115	D16	3139	J

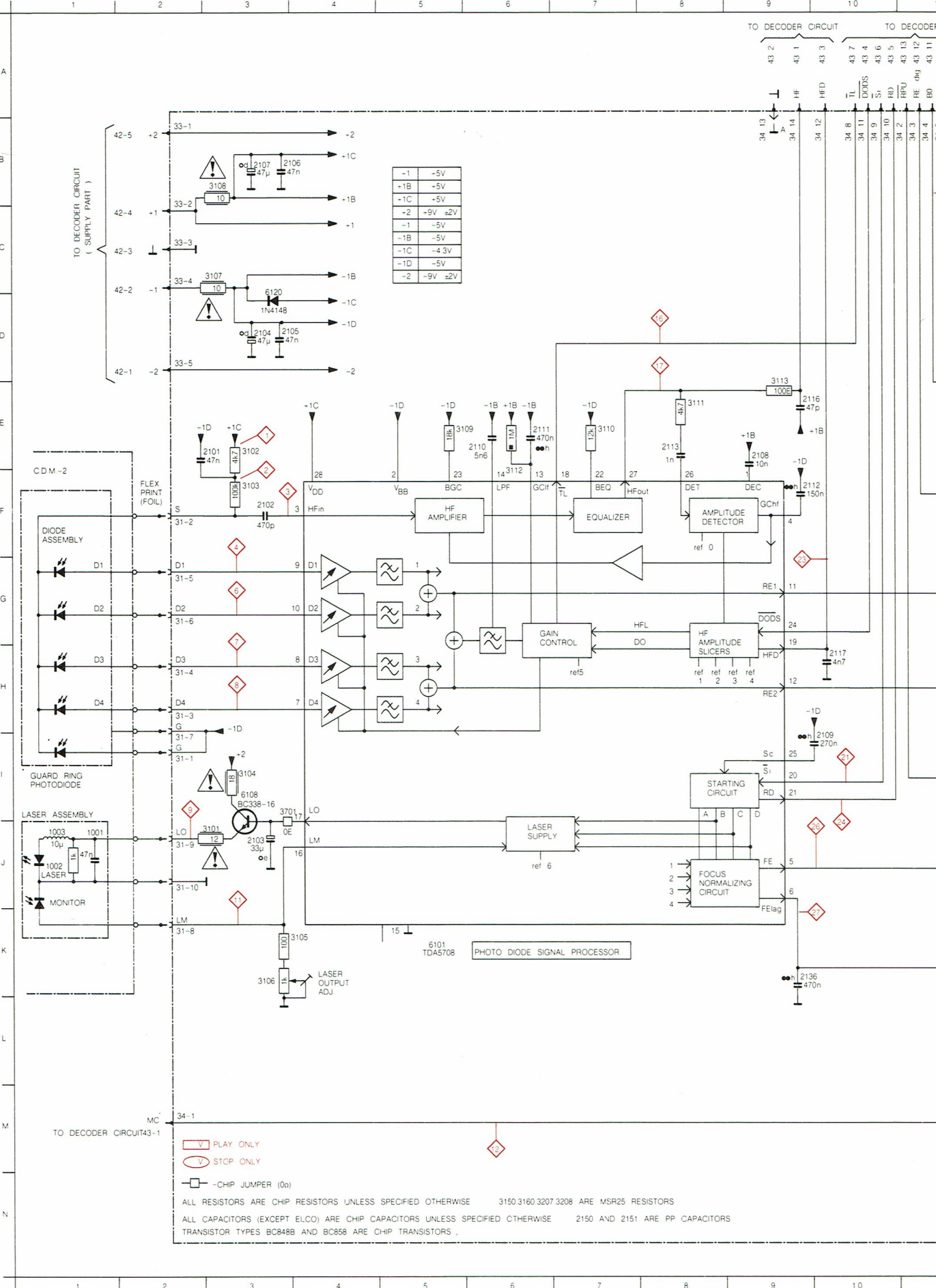

2	3140	K13	3144	K14	3154	E19	3158	I17	3162	F19	3201	L18	3206	L17	3701	I 3	3709	C17	6102	D12	6104	J13	6111	M19	6120	C 3
3	3141	K15	3150	H13	3155	F19	3159	F20	3163	F21	3202	M18	3207	L16	3702	G11	3710	C17	6103	L18	6108	I 3	6114	I17		
4	3142	J15	3151	F18	3156	I18	3160	G20	3168	E19	3204	M17	3208	M15	3703	H11	3712	G18	6103	L16	6109	I18	6118	E20		
5	3143	J15	3152	D19	3157	I17	3161	F20	3200	L18	3205	M17	3209	M15	3705	F11	6101	K 5	6104	E20	6110	M19	6119	F20		

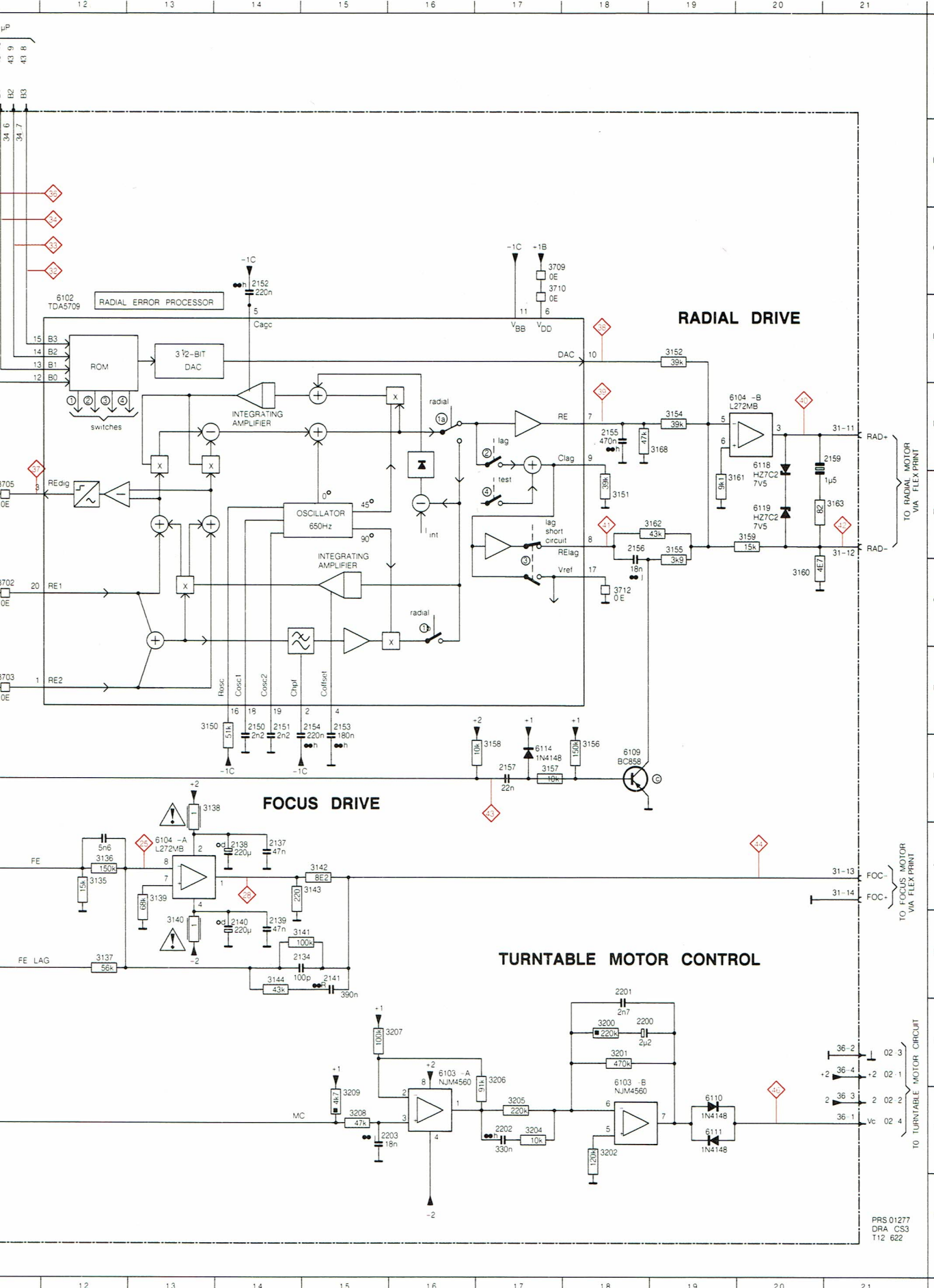



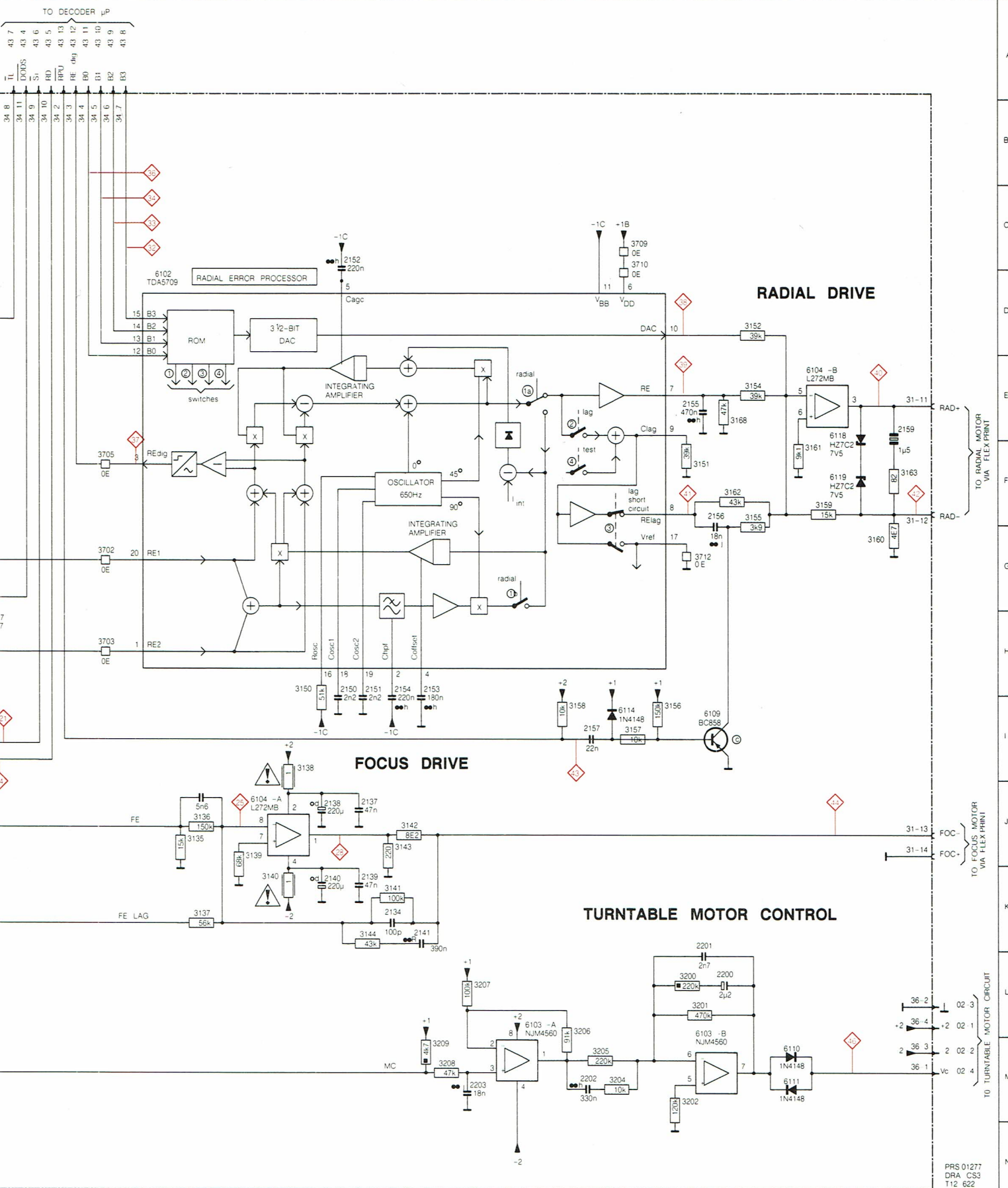

PRS 01277
DRA CS3
T12 622

12	D	F	8	9	3	12	3140	K13	3144	K14	3154	E19	3158	I17	3162	F19	3201	L18	3206	L17	3701	I 3	3709	C17	6102	D12	6104	J13	6111	M19	6120	C 3
13	D	F	8	9	3	12	3141	K15	3150	H13	3155	F19	3159	F20	3163	F21	3202	M18	3207	L16	3702	G11	3710	C17	6103	L18	6108	I 3	6114	I17		
14	D	F	8	9	3	12	3142	J15	3151	F18	3156	I18	3160	G20	3168	E19	3204	M17	3208	M15	3703	H11	3712	G18	6103	L16	6109	I18	6118	E20		
15	D	F	8	9	3	12	3143	J15	3152	D19	3157	I17	3161	F20	3200	L18	3205	M17	3209	M15	3705	F11	6101	K 5	6104	E20	6110	M19	6119	F20		



PRS 01277
DRA CS3
T12 622

ELECTRICAL PARTS IIA

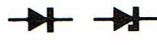
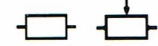
			 IC		
6101	TDA5708	4822 209 83202	28P	IC socket	4822 255 40156
6102	TDA5709	4822 209 83203	20P	IC socket	5322 255 44259
6103	NJM4560D	4822 209 83274	14P	Flex print connector	4822 290 60602
6104	L272MB	4822 209 83197			
					
6109	BC858B	5322 130 41983	2150,2151	3.6 nF-160 V-1%	4822 121 51001
6108	BC338-16	4822 130 40892	2159	1.5 μF- 50 V-131P	4822 124 21918
			For chip capacitors see list on page 5-6		
					
6110,6111	1N4148	4822 130 30621	3101	12 Ω-NFR25	4822 111 30511
6114,6120			3104	18 Ω-NFR25	4822 111 30515
6118,6119	HZ7C2	4822 130 32862	3106	1 kΩ-Trimpot	4822 100 20151
			3107,3108	4.7 Ω-NFR25-5%	4822 111 30499
			3138,3140	1 Ω-NFR25	4822 111 30483
			3160	4.7 Ω-MRS25	4822 116 52858
			For chip resistors see list on page 5-8		