

20..	04															01	06	
30..	44+46	76.75.78.08+14.01-07.73.74.77.59.58	56	84	52	53.99.82.79.86.83.19+21.47-49.80.81.55.25-27	15-18.24.28.22.23	50	51	54	57	43	85					
31..	00	01																
60..	01	53	51	04	03	05.08	52	06	16.18.07.17	15	02							
70..	52	55	63	51	65		64	62	61	54	53							

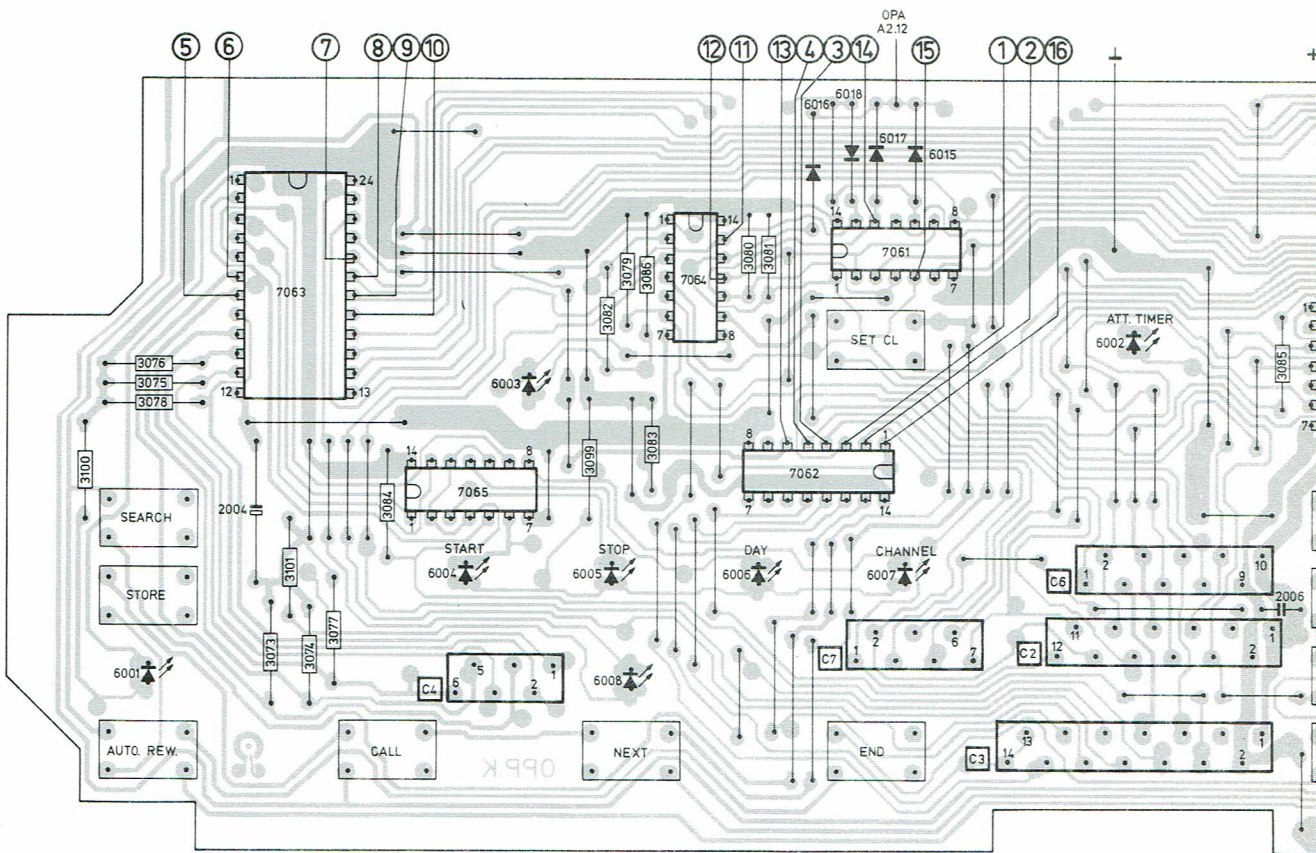

53.99	82.79	86.83	19+21.47	-49.80	81.55	25+27	15+18	24	28	22	23	50	51	54	57	43	85	72	31+33	41	36	37	38	42	29	30	35	34	39	40	16	17	20	18	05	07		
05.08	52	06	62	16	18	07	17	15	54	02	53	56	60	57	59	54																						

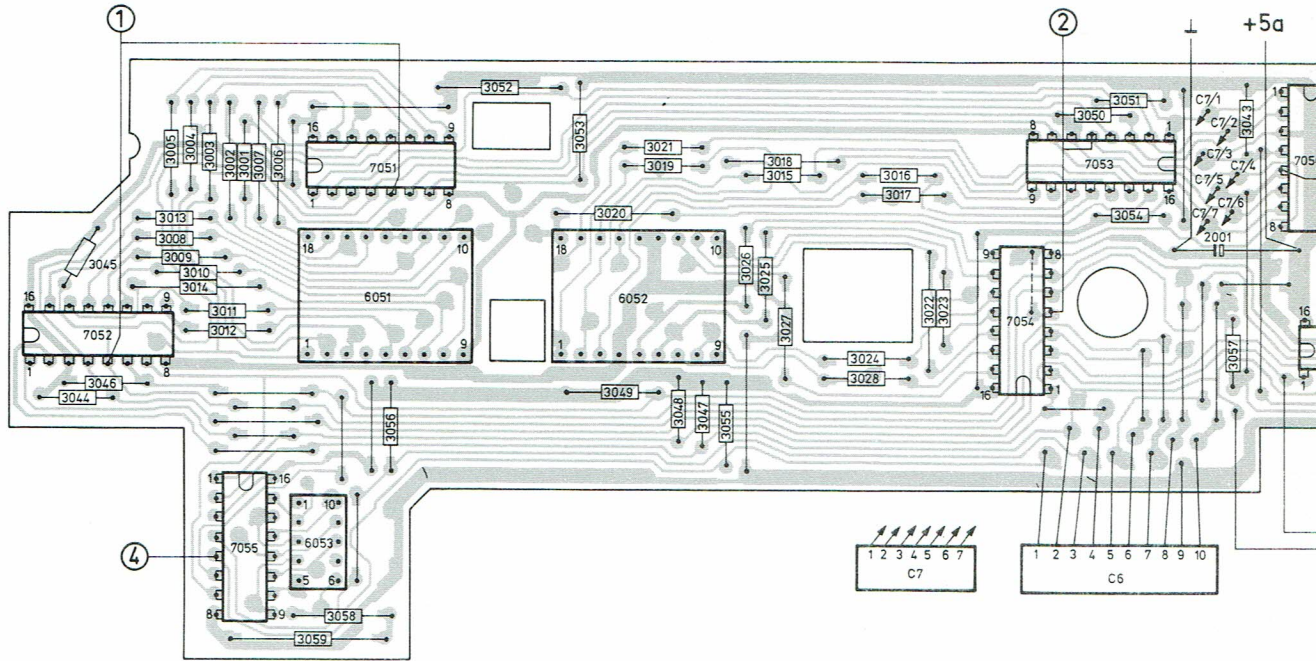

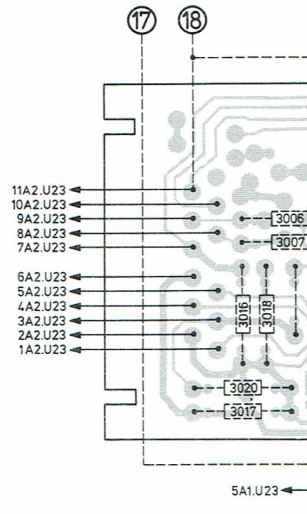
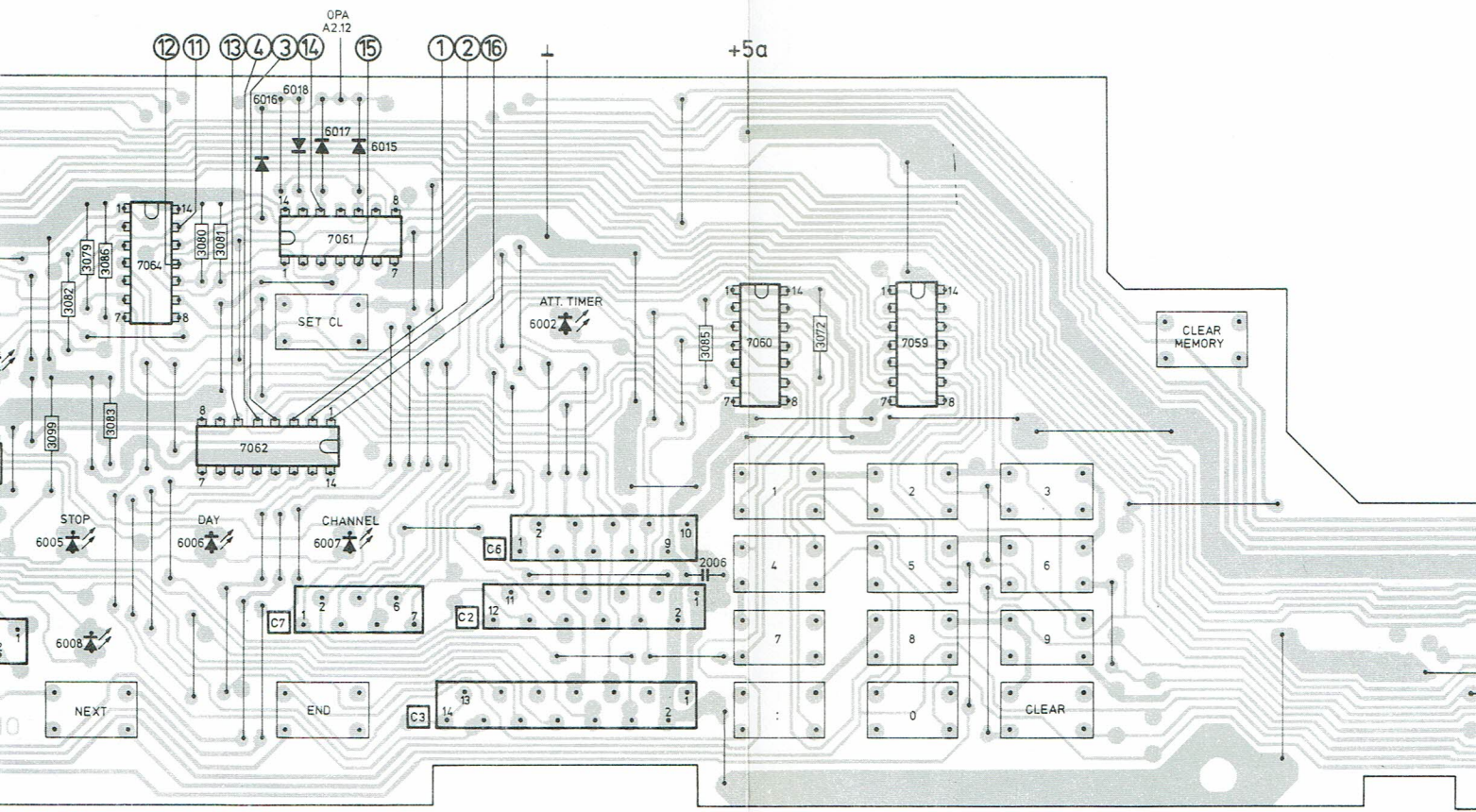
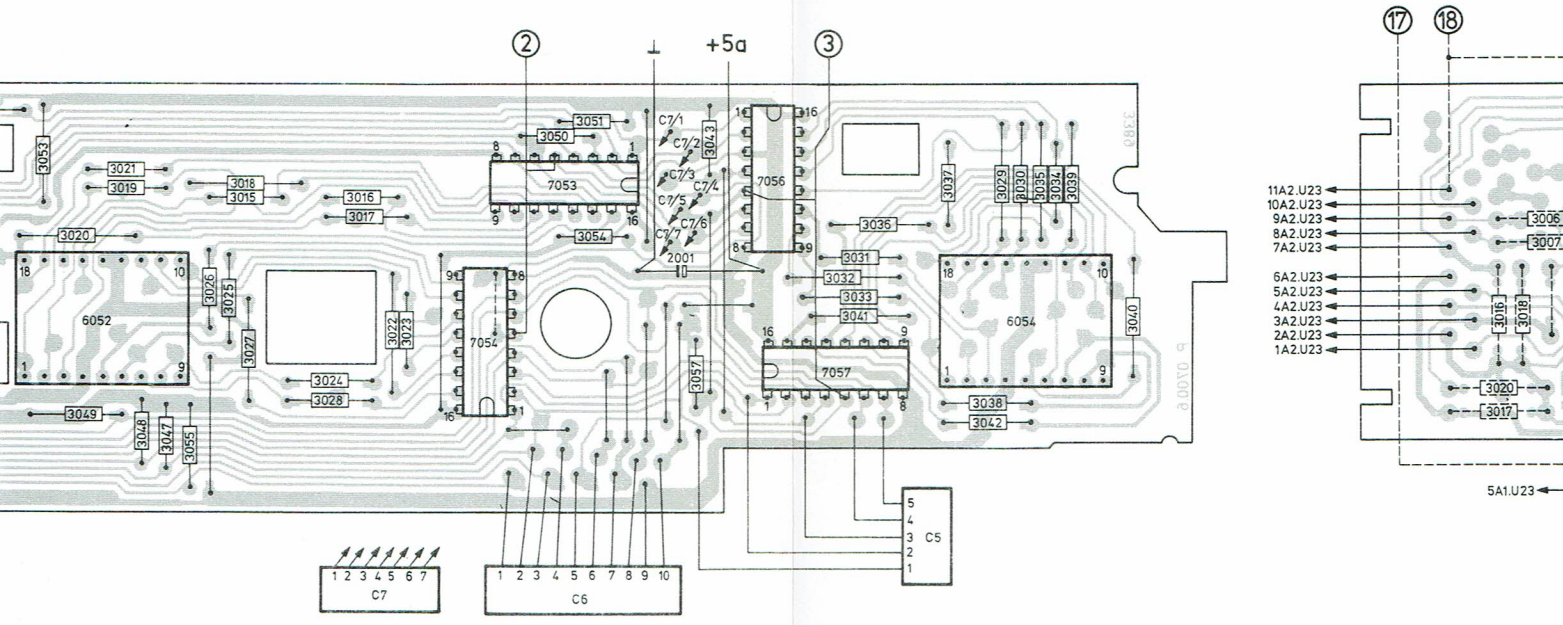
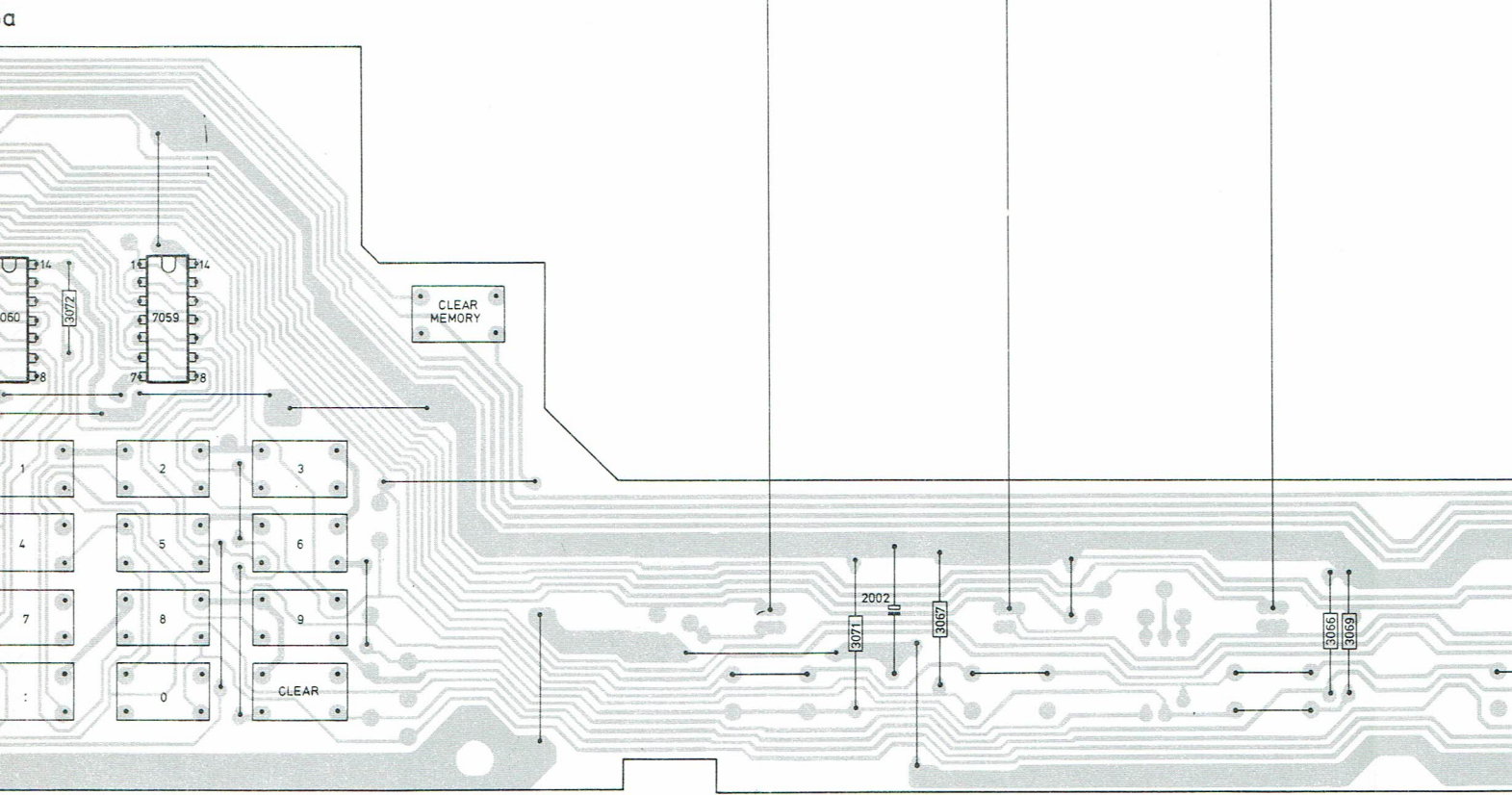
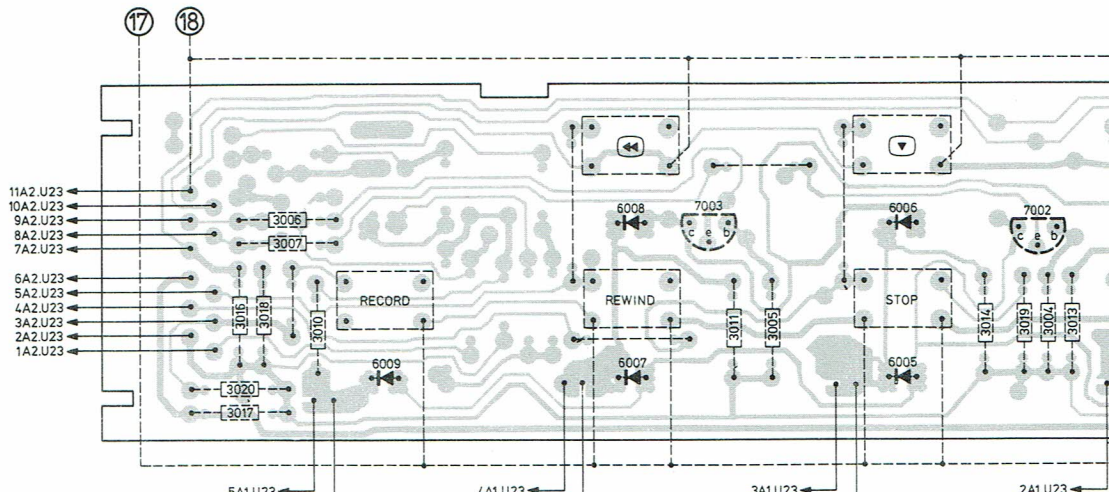
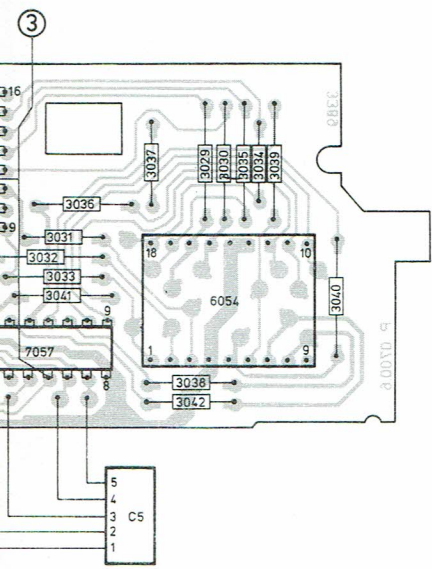

										03					05									
14	19	04	13	70	68	12	94	95	96	97	65	92	93	87-91	98									
					02					56					55									
03.04					01.02					04					03 58					02 01				
02																								

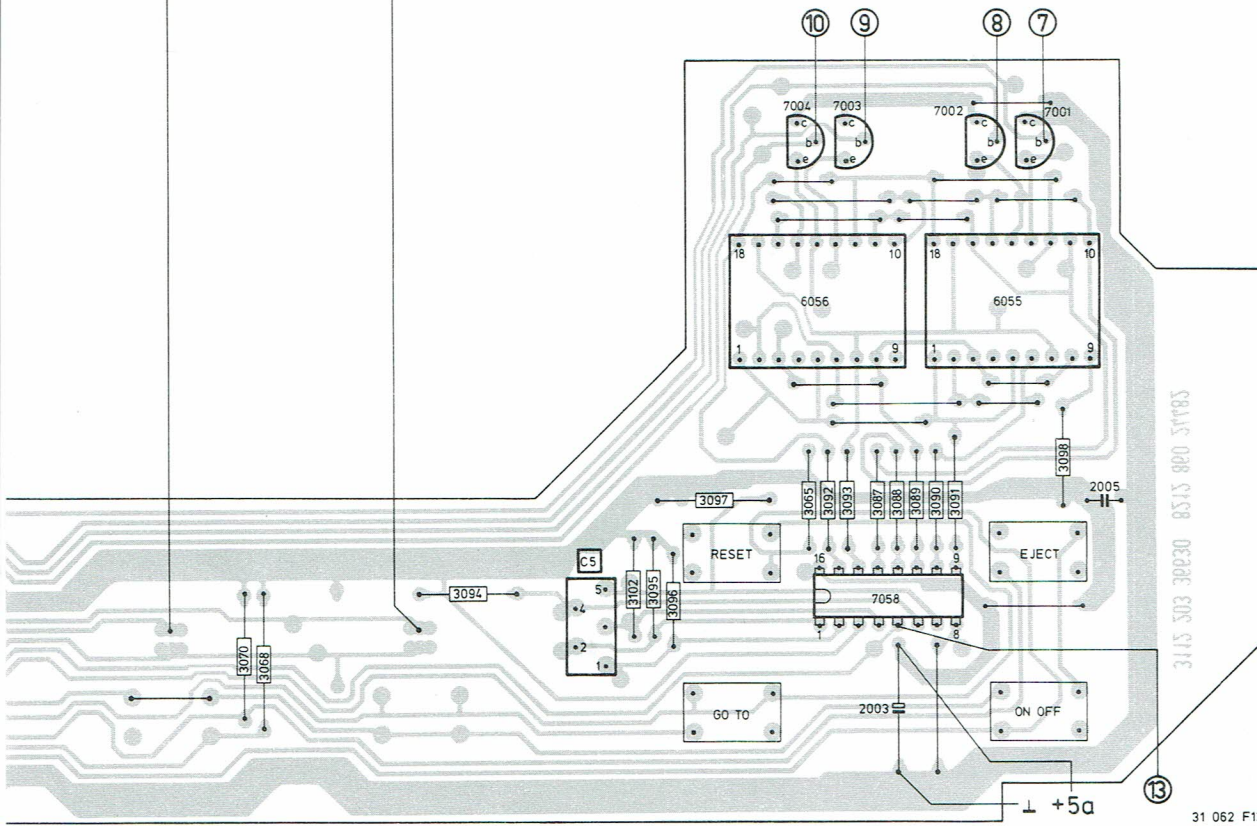
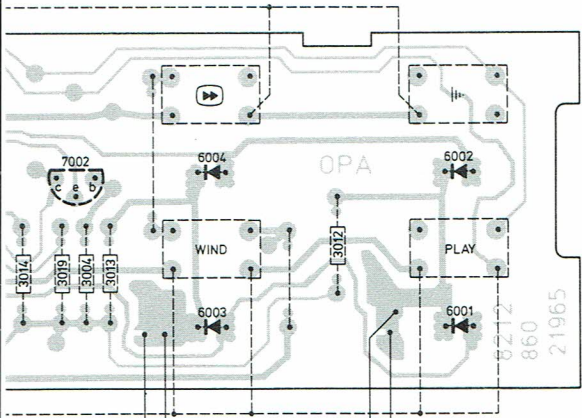

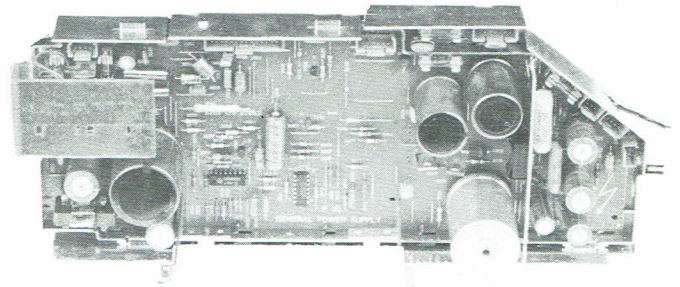







3p		4822 267 40352	2012	220 nF - 100 V	4822 121 50767			
4p		4822 267 40353	2013	100 nF - 100 V	4822 121 40522			
6p		4822 267 40355	2014	4700 µF - 40 V	4822 124 70326			
7p		4822 267 50285	2015	3.3 nF - 50 V	4822 122 10156			
14p		4822 267 50289	2016	15 nF - 400 V	4822 121 20205			
			2017	3.3 nF - 50 V	4822 122 10156			
			2018	1500 µF - 16 V	4822 124 20778			
			2019	2200 µF - 16 V	4822 124 20779			
			2020	100 nF - 250 V	4822 121 40518			
			2021	100 nF - 630 V	4822 121 41398			
			2022	33 µF - 160 V	4822 124 21089			
			2023	150 µF - 63 V	4822 124 20799			
			2024-2025	33 µF - 250 V	4822 124 21092			
			2032	100 nF - 100 V	4822 121 40522			
			2033	1.5 µF - 25 V	4822 124 20942			
			2034	3.3 µF - 16 V	4822 124 20947			
			2036	2.2 nF - 100 V	4822 122 30114			
			2037	10 nF - 50 V	4822 122 31375			
			2040	100 µF - 40 V	4822 124 20715			
			2051	100 nF - 100 V	4822 121 20206			
			2053	22 µF - 40 V	4822 124 20907			
			2054	100 nF - 100 V	4822 121 40522			
			2055	100 nF - 100 V	4822 121 20206			
			2056-2058	135 µF - 12 V	4822 124 21066			
			2057	100 nF - 250 V	4822 121 20204			
			2060-2061	22 nF - 63 V	4822 122 30103			
			2062	135 µF - 12 V	4822 124 21161			
			2063	22 nF - 63 V	4822 122 30103			
			2070	2.2 nF - 100 V	4822 122 30114			
			2071	150 µF - 16 V	4822 124 20903			
			2072	100 nF - 100 V	4822 121 40522			
			1001-1002	3.15 A	4822 253 30027			
			1003	0.315 A	4822 253 30014			
			1005	4 A	4822 253 30051			
			1006	4 A	4822 253 20026			
2001	100 nF - 100 V	4822 121 40522						
2002	2200 µF - 40 V	4822 124 40351						
2003	3300 µF - 25 V	4822 124 40371						
2005	3.3 µF - 16 V	4822 124 20947						
2006	15000 µF - 25 V	4822 124 21084						
2008	680 µF - 16 V	4822 124 20776						
2011	68 µF - 16 V	4822 124 20902						

For circuit diagram of P32 see page 3-16 and for spare parts lay-out page 3-17.

Voor het princieschema van P32 zie pagina 3-16, en voor de onderdelen-opstelling pagina 3-17.

Für das Prinzipschaltbild von P32 siehe Seite 3-16 und für den Einzelteillayout Seite 3-17.

Pour ce qui est du schéma de principe de P32, voir p. 3-16 et pour la disposition des éléments, p. 3-17.

					
3009	133 Ω - 1 %	4822 116 51334	BC547		4822 130 44257
3036	0.1 Ω - 5% - 2 W	4822 113 60128	BD646		4822 130 41212
3067-3068	1.5 k Ω - 5%	4822 116 51239			
					
			SG3524NS25ST		4822 209 80585
5003		4822 157 51189	UA339PC		4822 209 80815
5004		4822 157 51016			
5012		4822 157 51188			
5014		4822 157 51188			
					
BAT43		4822 130 31353	Clamping spring for 6001 and 6005	}	4822 492 62181
BYS2C		4822 130 31425	Klemveer voor 6001 en 6005		
BZW22/C47		4822 130 31496	Klemmfeder für 6001 und 6005		
BZX79/B5V6		4822 130 34173	Ressort de serrage de 6001 et 6005	}	4822 492 62242
BZX79/B13		4822 130 34195	Clamping spring for 7015		
GP20A		4822 130 31059	Klemveer voor 7015		
GP30A		4822 130 31349	Klemmfeder für 7015	}	4822 466 90901
KBL02P		4822 130 50322	Ressort de serrage de 7015		
RGP10G		4822 130 31201	Insulation plate for 7015		
1N4148		4822 130 30621	Isolatieplaat voor 7015	}	4822 466 90901
			Isolierplatte für 7015		
			Plaque d'isolation de 7015		
					
BSTD1006M		4822 130 20108			
C103YY (TAGBRX45X)		4822 130 20085			
TAG92DP		4822 130 20105			
TAG661/100X		4822 130 20107			

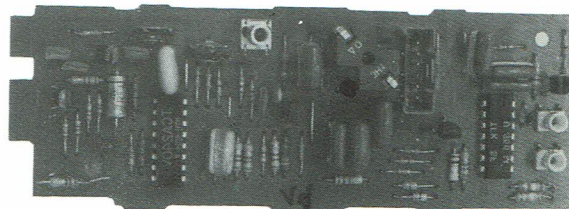

24 579 A12

2004	100 nF - 100 V	4822 121 40522	BAW62	4822 130 30613
2005	100 nF - 100 V	4822 121 40522		
2007	68 nF - 100 V	4822 121 41435		
2010	22 nF - 250 V	4822 121 41437		
2014	47 nF - 100 V	4822 121 41434	J107	4822 130 41688
2015	47 nF - 100 V	4822 121 41434	J309	4822 130 41398
			BC549B	4822 130 40936
3023	10 Ω	4822 111 30508	BF495	4822 130 40947
			BF689K	4822 130 41404
3028	470 Ω	4822 100 10392	TCA240V	4822 209 80737
3029	220 Ω	4822 100 10391	U356M	4822 209 80974
5001		4822 156 10499		
5002		4822 156 10499		
5003		4822 157 10095		
5004		4822 157 51003		
5005		4822 156 20857		

P52**Adjustments**

- 3028 (frequency characteristic)
 - 3029 (balance)
- These are recorder adjustments, for which reference is made to Chapter Recorder adjustments on page 2-2 of this Manual.

P52**Réglages**

- 3028 (réponse de fréquence)
 - 3029 (balance)
- Il s'agit des réglages à l'appareil, se reporter à cet effet au chapitre en cause, p. 2-2 de cette Documentation.

P52**Instellingen**

- 3028 (frequentie karakteristiek)
 - 3029 (balans)
- Dit zijn apparaat-instellingen. Zie voor deze instellingen hoofdstuk "Apparaat instellingen" op blz. 2-2 van deze documentatie.

P52**Einstellungen**

- 3028 (Frequenzkurve)
 - 3029 (Balance)
- Dies sind Geräte-Einstellungen, siehe für diese Einstellungen den Abschnitt "Geräte-Einstellungen" auf Seite 2-2 dieser Anleitung.

20.	04.09.06	10.11.12	13	15	17	02	05.14	08	07	18.16.19	
30.	44.02.46.01.09+15	38+40	42.03+05	24	18.20	32	17.41.25+30.22.19.33.45.37	08.07		43.31.06.21.34+36	23
50.	06	01.02					05	03		04	
60.	01.02						03	04			
70.	01	02.06	52	53			03	53	05	04	

P52 HEADAMPLIFIER

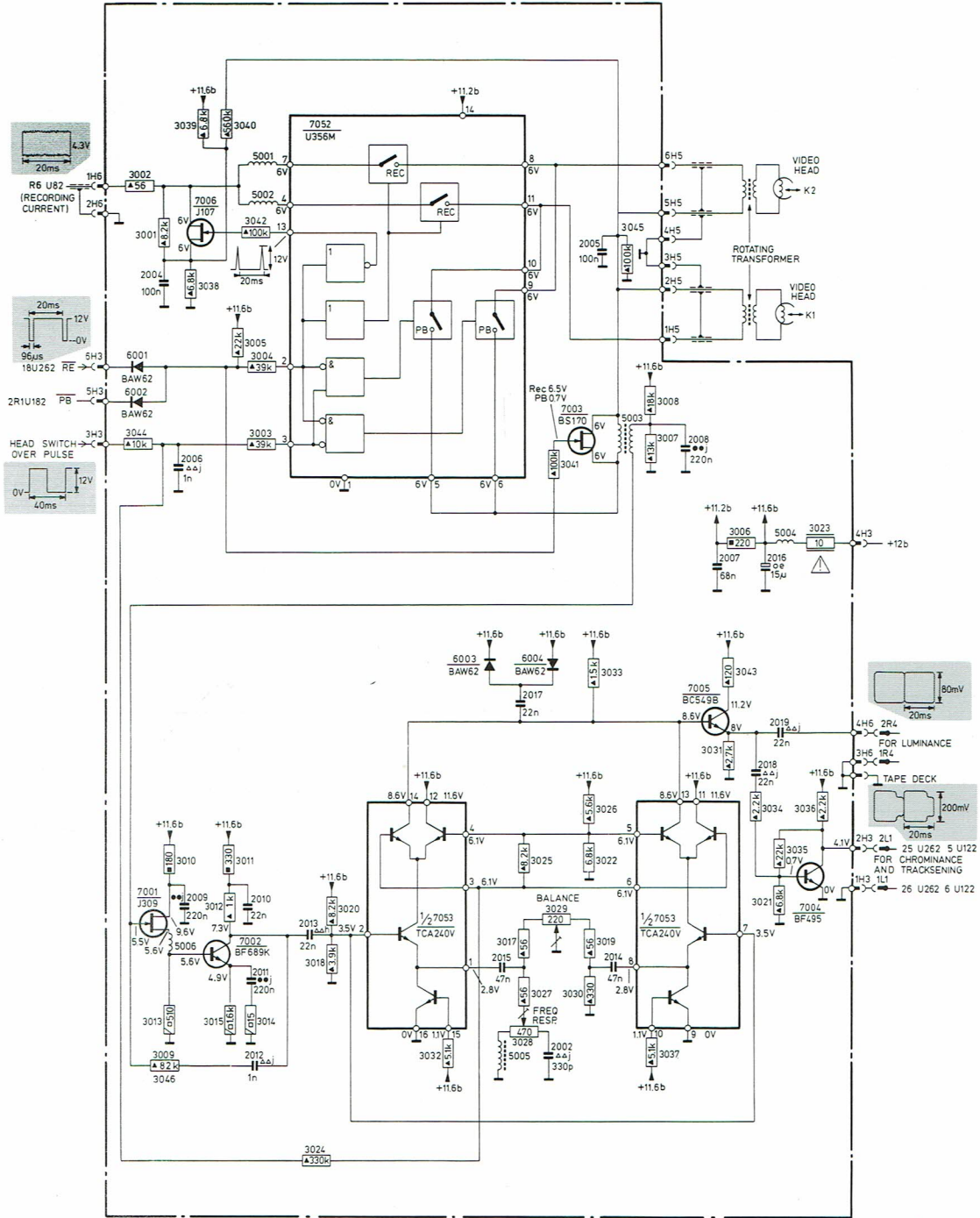

24 584 E12

MISC.	6003, 6004, 5004	5005	5003	6001, 6002	5001, 5002
70.	04	05	53	02	01
20.	19.18	17	16.02	14	13
30.	35.36.43.21.23.31.34	33.32.37.28	27.17.30.29.26.19.24.20.18.44.25.22.11	12.15.16	10
				09.08	07
				05.39.06	03
				41	40
				07.04	01
				42.38	01+04

P52

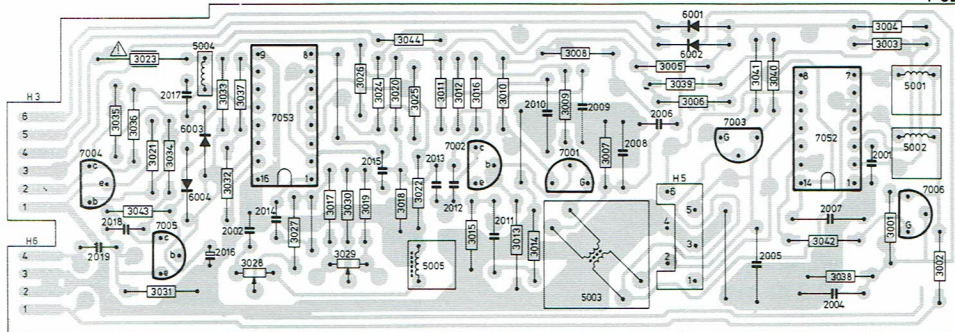

24257D10

P60-a- P60-b -P61-P62-P63-P64-P65-P66



P60-a

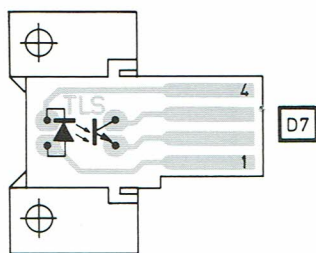

24 992A12

P60-b

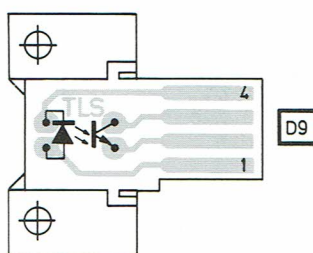

24 993A12

P61

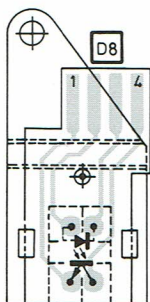

19416 A 13/A

P64

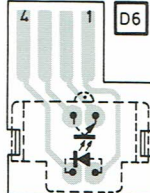

19415 A 13

P63 CASSETTE SWITCHES

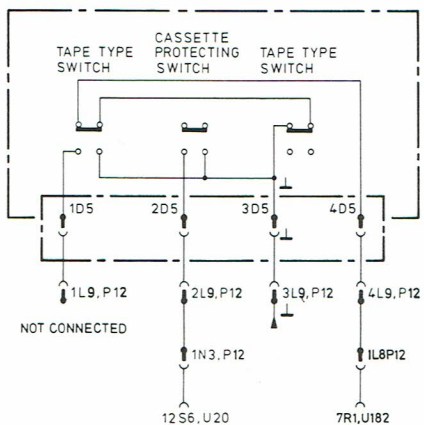

REMARK : SWITCHES POSITION WITHOUT CASSETTE INSERTED

24 967 A12

P63 (KSP)

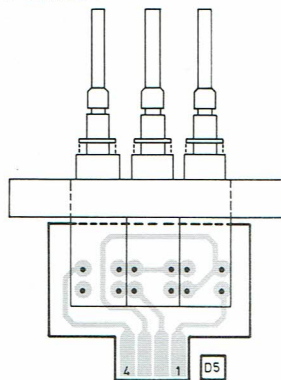

19412 A 13

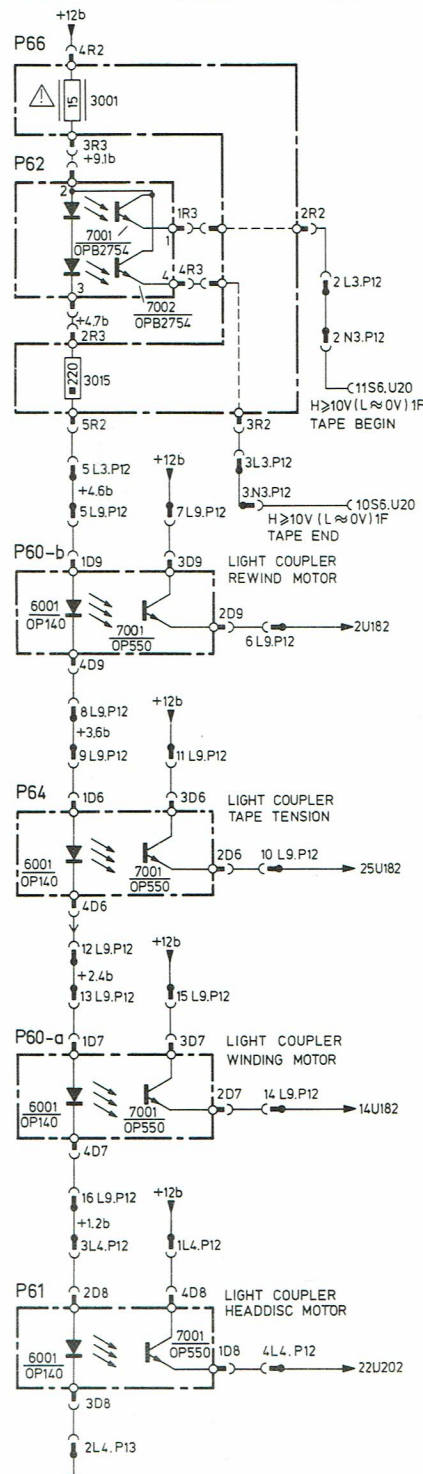

24 965 D12

20..	01		04		02.03	
30..	15.18.19.09.12.11.10.13.03÷08				14	17.16.01
MISC.	7001.7002	1÷4R3	6001.6002	7051	2x7052	1÷6R2.6.7L3.2.3N3.10.11S6

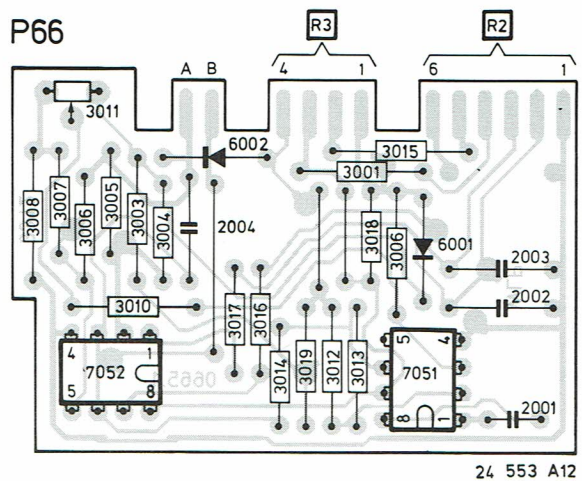
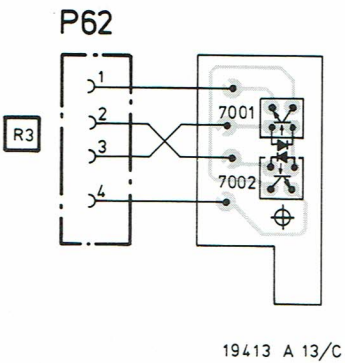
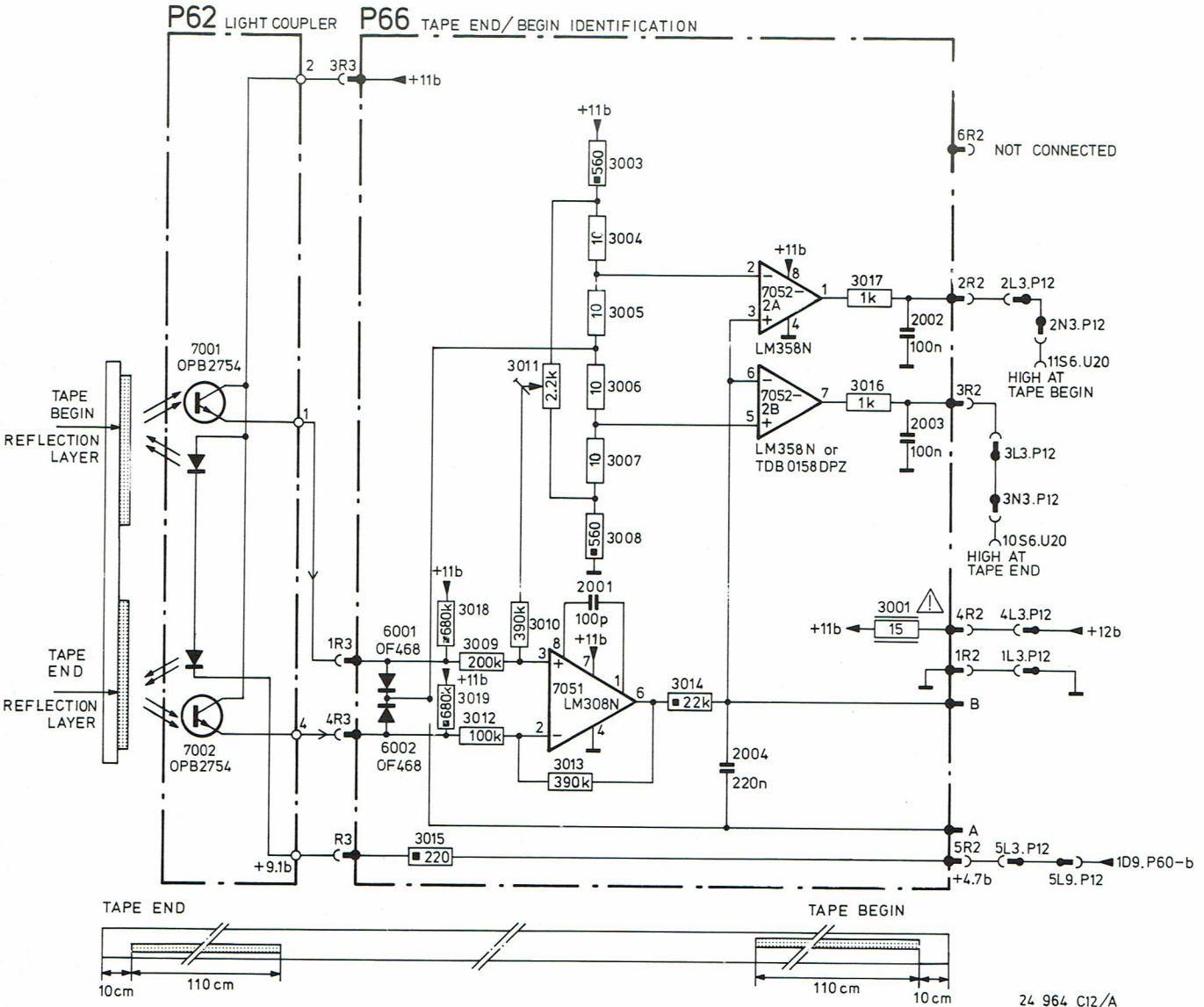

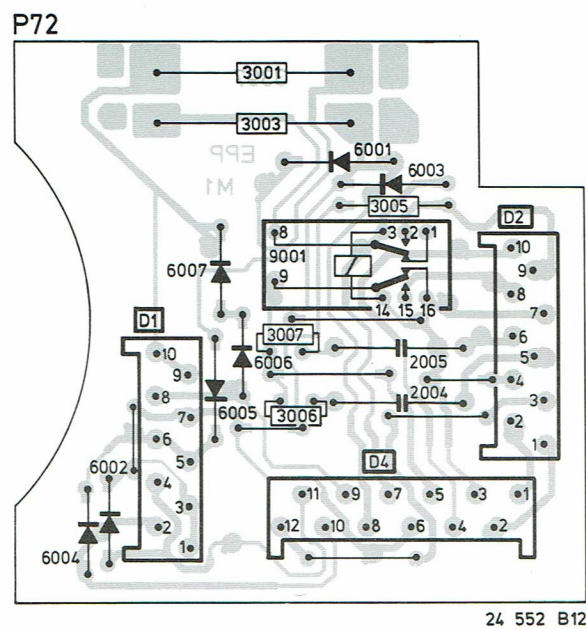
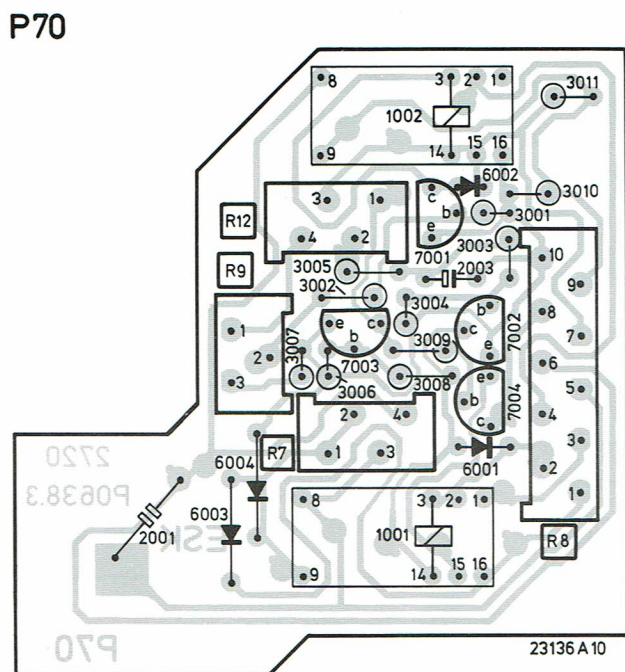
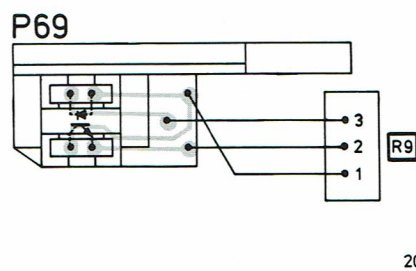
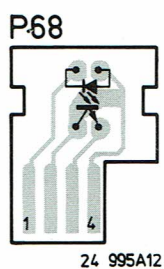

P80

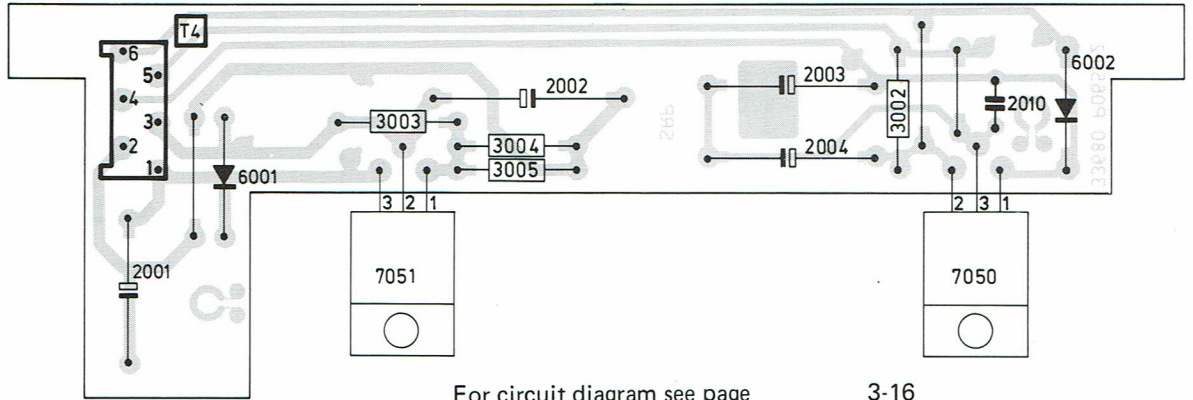

For circuit diagram see page 3-16
 Voor prinseschema zie pagina 3-16
 Für Prinzipschaltbild siehe Seite 3-16
 Pour le schéma de principe voir page 3-16

21703 B13/C

P85

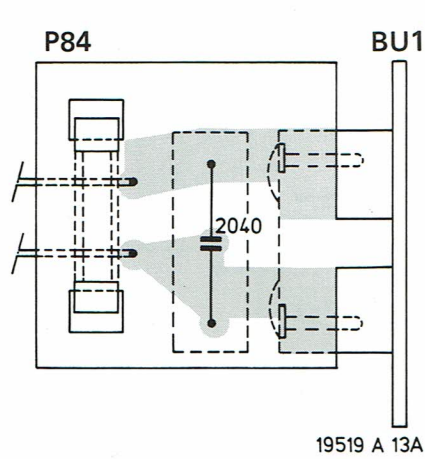

For circuit diagram see page 3-16
 Voor prinseschema zie pagina 3-16
 Für Prinzipschaltbild siehe Seite 3-16
 Pour le schéma de principe voir page 3-16

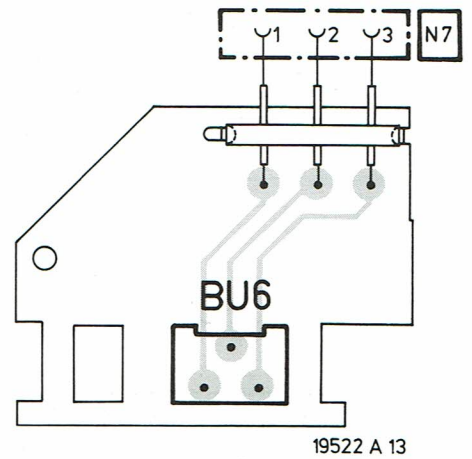

For circuit diagram see page 3-14
 Voor prinseschema zie pagina 3-14
 Für Prinzipschaltbild siehe Seite 3-14
 Pour le schéma de principe voir page 3-14

P86

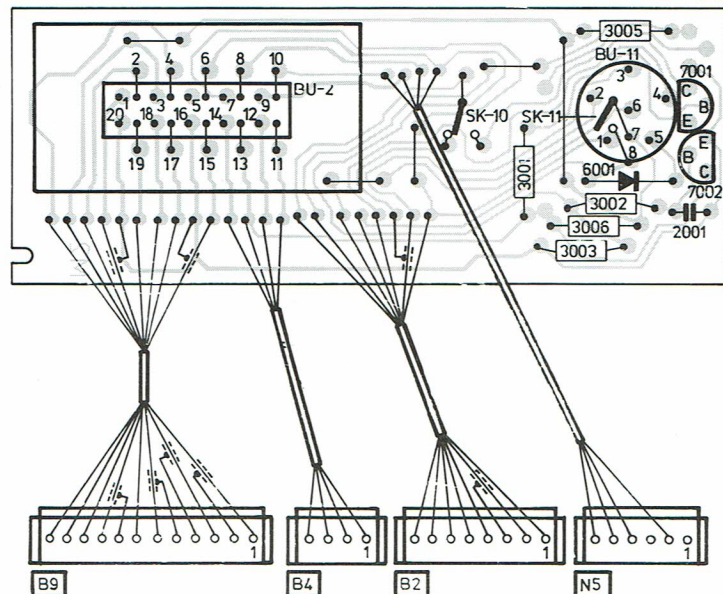

29 431 A12

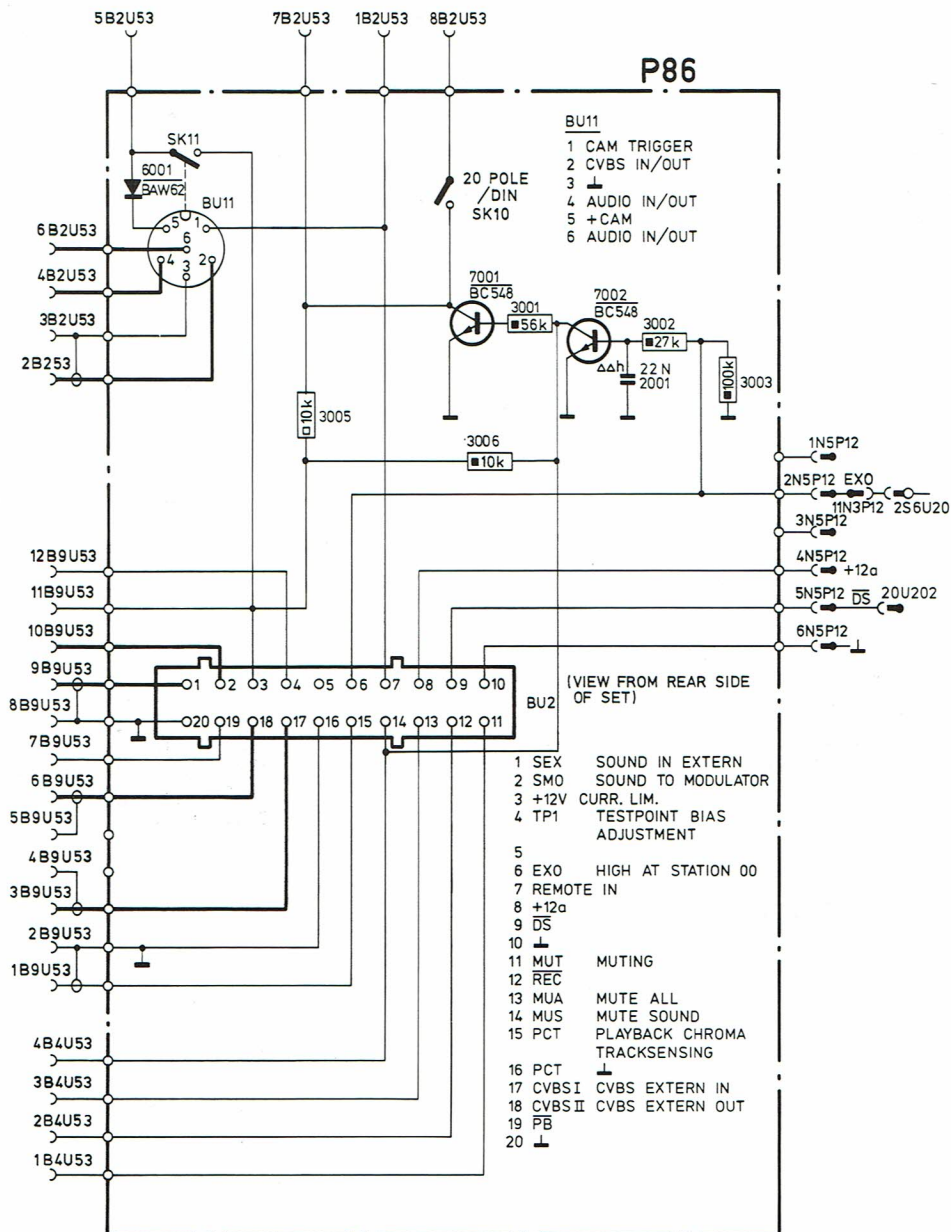

29338 C2

P80

P86

			BU-2	4822 267 60108
			SK-10	4822 273 40305
6p		4822 267 40355	BU-11+SK-11	4822 267 40456
			Knob for SK-10	4822 413 31038
2001	15 μ F - 40 V	4822 124 21083		
2002	33 μ F - 6.3 V	4822 124 21081	C2001	22 nF/63 V
2003	15 μ F - 40 V	4822 124 21083		
2004	33 μ F - 16 V	4822 124 20905		
2010	100 nF - 63 V	4822 121 41597		
			BAW62	4822 130 30613
RGP10G		4822 130 31201		
			BC548	4822 130 40938
LM317T		4822 209 80591		
μ A7812AGKCS		4822 209 80816		

P80

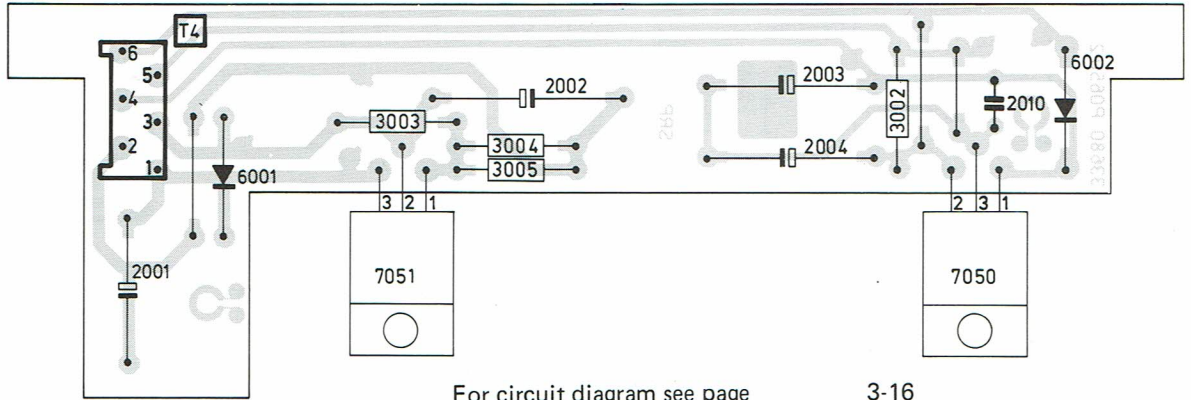

For circuit diagram see page 3-16
 Voor princieschema zie pagina 3-16
 Für Prinzipschaltbild siehe Seite 3-16
 Pour le schéma de principe voir page 3-16

21703 B13/C

P85

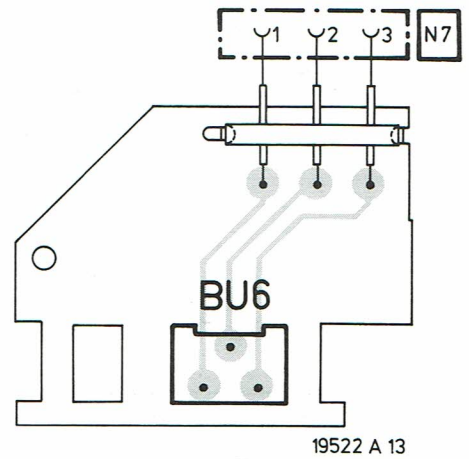
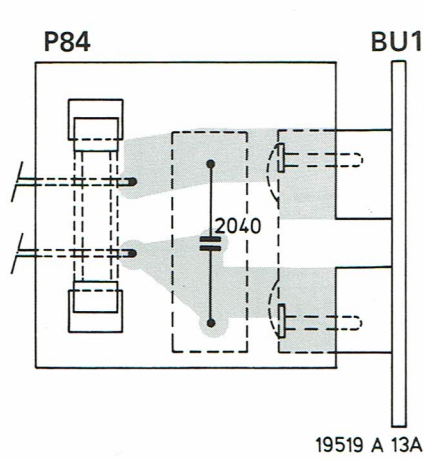

For circuit diagram see page 3-16
 Voor princieschema zie pagina 3-16
 Für Prinzipschaltbild siehe Seite 3-16
 Pour le schéma de principe voir page 3-16

For circuit diagram see page 3-14
 Voor princieschema zie pagina 3-14
 Für Prinzipschaltbild siehe Seite 3-14
 Pour le schéma de principe voir page 3-14

P86

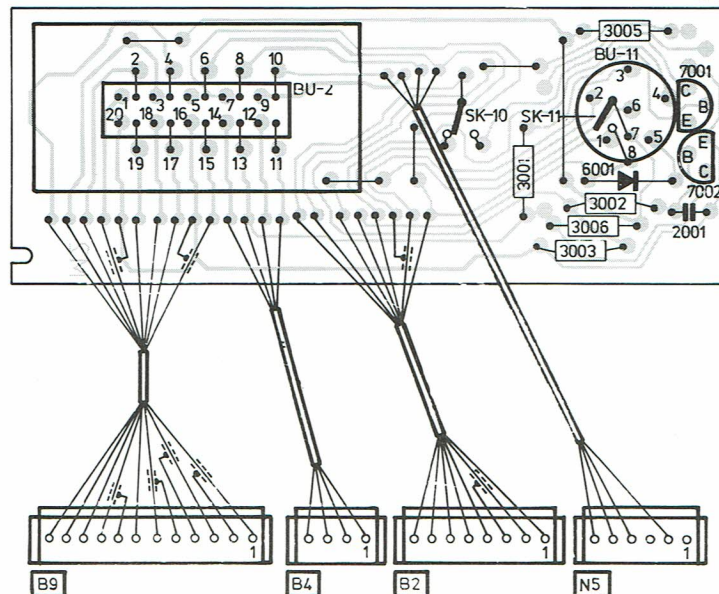

29 431 A12